



FEDERATION INTERNATIONALE
DE L'AUTOMOBILE

Homologation N°

2023-06-XCAR-MT07

XC Engine
YAMAHA MT07 2016-2023

FICHE D'HOMOLOGATION
HOMOLOGATION FORM

Homologation valable à partir du
Homologation valid as from

23/06/2023

1. GENERALITES / GENERAL

101. CONSTRUCTEUR / MANUFACTURER

YAMAHA

3. MOTEUR / ENGINE

307. CYLINDRÉE MAXIMALE / MAXIMUM CYLINDER CAPACITY

a) Unitaire Unitary	344.6	cm3
b) Totale Total	689.2	cm3

309. MASSE MINIMUM / MINIMUM WEIGHT

a) Pesé comme décrit dans le règlement et photos Weighted as described in the regulations and photos	51.5	kg
---	------	----

314. ALÉSAGE / BORE

80.06	+0 - 0.1 mm
-------	----------------

316. COURSE / STROKE

68.45	+0 - 0.1 mm
-------	----------------

C1-1) Moteur déposé – vu de profil
Dismounted engine – seen from the side



C1-2) Moteur déposé – vu de profil
Dismounted engine – seen from the side



C1-3) Couvre culasse - déposé
Cylinderhead cover - dismounted



C1-4) Couvre culasse - déposé
Cylinderhead cover - dismounted

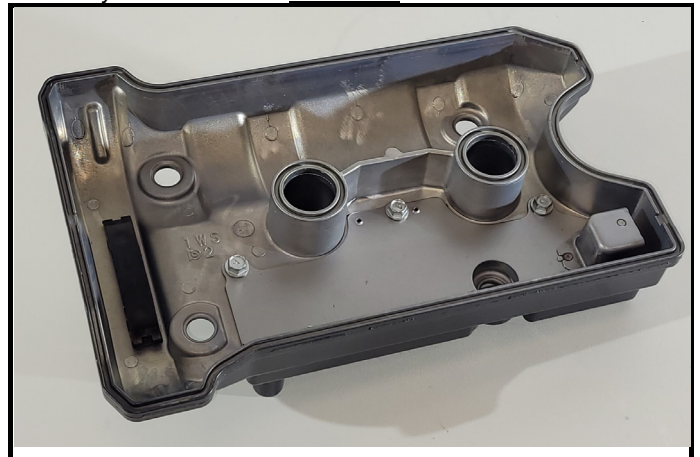

311. BLOC-CYLINDRES / CYLINDER BLOCK

a) Matériau
Material

Aluminium

C3-1) Bloc-cylindre nu vu de dessus
Bare cylinder block seen from above

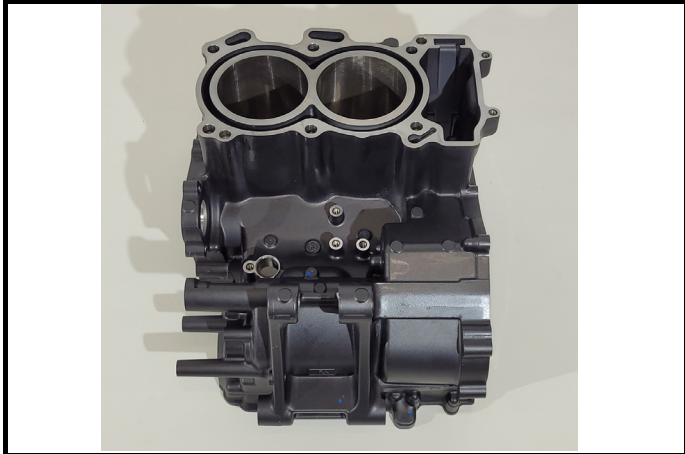

C3-2) Bloc-cylindre nu vu de dessous
Bare cylinder block seen from underneath



C3-3) Bloc-cylindre nu vu côté droit
Bare cylinder block seen from right hand side



C3-4) Bloc-cylindre nu vu de côté gauche
Bare cylinder block seen from left hand side

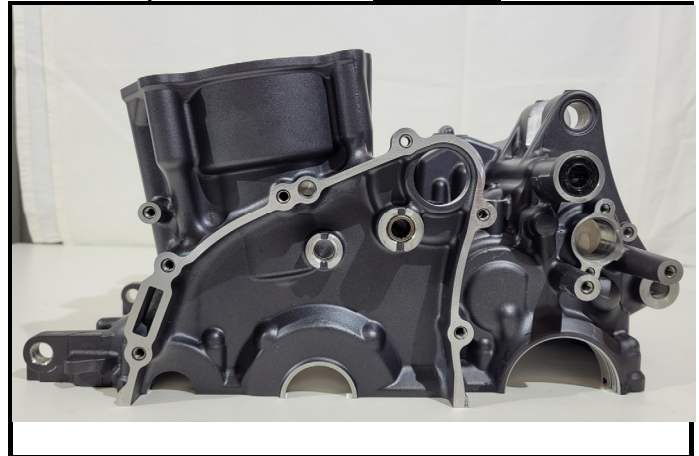

C3-5) Bloc-cylindre nu vu côté Echappement
Bare cylinder block seen from exhaust side

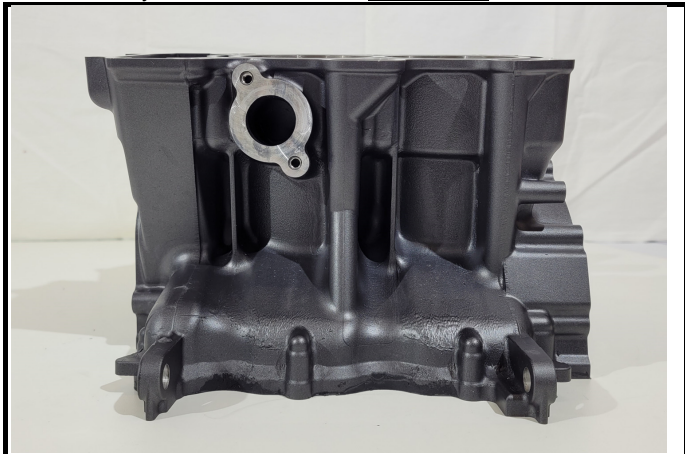

C3-6) Bloc-cylindre nu vu de côté Admission
Bare cylinder block seen from intake side

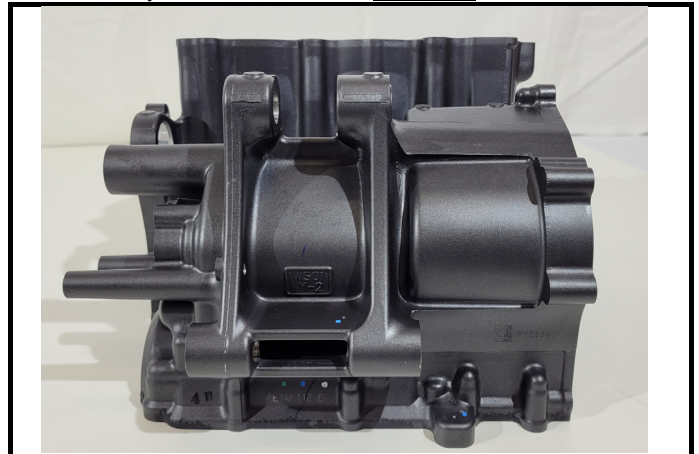

C3-7) Chapeaux de paliers de vilebrequin
Crankshaft bearing caps

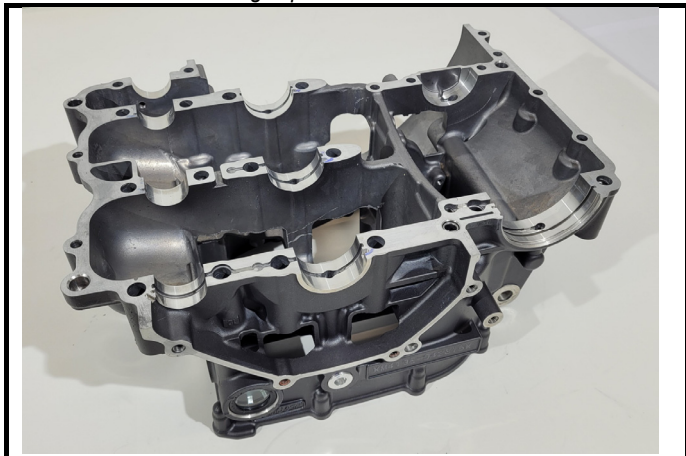

C3-8) Numéro de série sur le bloc moteur
Serial number on engine block

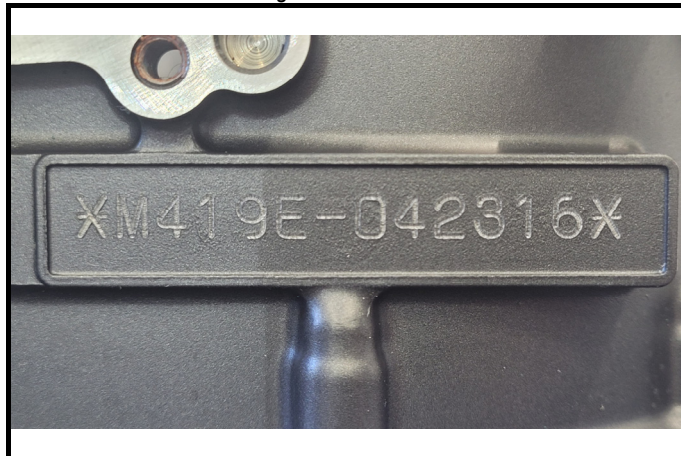

307. SYSTÈME D'ARBRES D'ÉQUILIBRAGE / BALANCING SHAFT SYSTEM

- | | | |
|---|------------------------|---------|
| a) Matériau des arbres d'équilibrage
Balancing shafts material | Acier
Steel | |
| b) Masse des arbres d'équilibrage
Balancing shafts weight | 841 | +/- 5 g |

C3-9) Arbres déquilibrage - démontés
Balancing shafts - dismounted

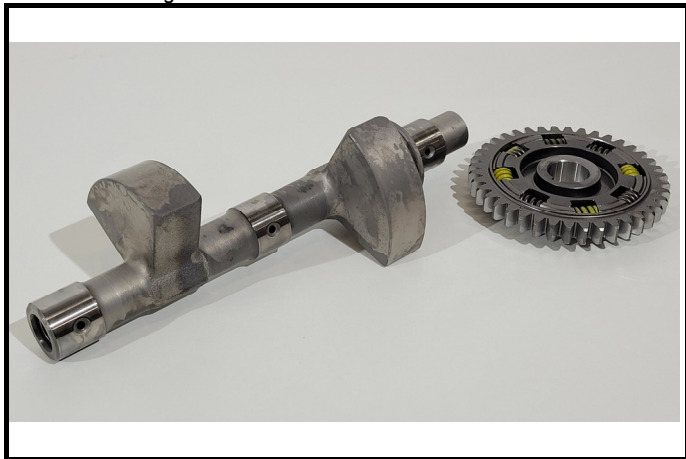

C3-10) Arbres déquilibrage - démontés
Balancing shafts - dismounted



312. HAUTEUR MIN. DU BLOC-CYLINDRES / MIN. HEIGHT OF THE CYLINDER BLOCK

III-C1) Mesure de la hauteur / Height measurement

a) Entre plans de joint carter et culasse
Between sump and head gasket planes **180.17** mm

b) Entre axe vilebrequin et plan de joint culasse
Between crankshaft centreline and head gasket plane Not applicable mm

313. CHEMISES / SLEEVES

a) Bloc cylindres chemisé <i>Sleeved cylinder block</i>	Oui / Yes <input type="checkbox"/>	Non / No <input checked="" type="checkbox"/>
b) Matériau <i>Material</i>	Nikasil	
c) Type <i>Type</i>	Humides <i>Wet</i> <input type="checkbox"/>	Sèches <i>Dry</i> <input checked="" type="checkbox"/>

C3-8) Chemise démontée (Origine)
Sleeve dismantled (Original)

Not applicable

C3-9) Chemise démontée (Réparation)
Sleeve dismantled (Repair)

Not applicable

317. PISTON / PISTON

- | | | | |
|---|------------------|--|---|
| a) Matériau
Material | Aluminium | | |
| b) Nombre de segments
Number of rings | 3 | b1) Epaisseur des segments
Thickness of rings | 0.9 - 1.0 - 1.5 + 0.1
-0.05 mm |
| c) Poids minimum
Minimum weight | 261 | g | <u>Avec axe, bagues, clips et segments</u>
<u>With pin, bearing, clips and rings</u> |
| d1) Hauteur de compression maximale
Maximum compression height | | | 25.15 / 22.15 mm |

C4-1) Piston de ¾ dessus
Piston from ¾ top



C4-2) Piston de ¾ dessous
Piston from ¾ bottom



C4-3) Piston segments
Piston rings

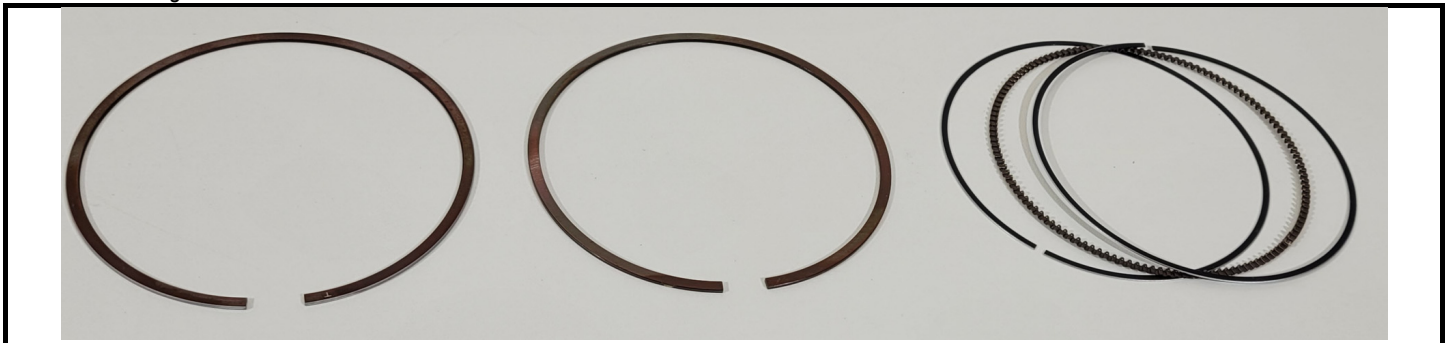

III-D1) Axe de piston
Piston pin

± 0.1 mm tolerance

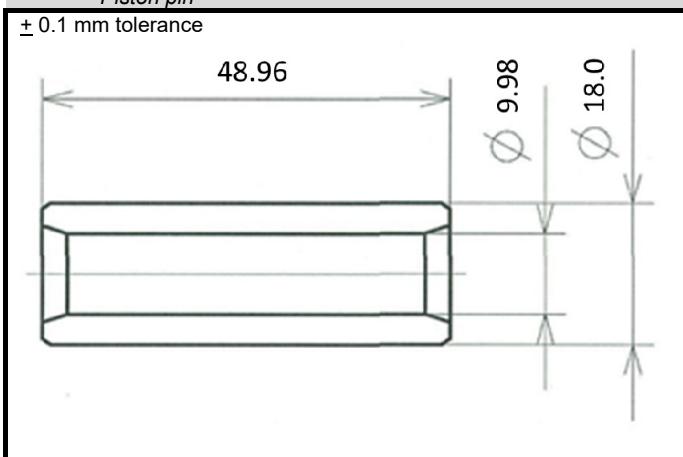

III-D2) Hauteur de compression maximale
Maximum compression height

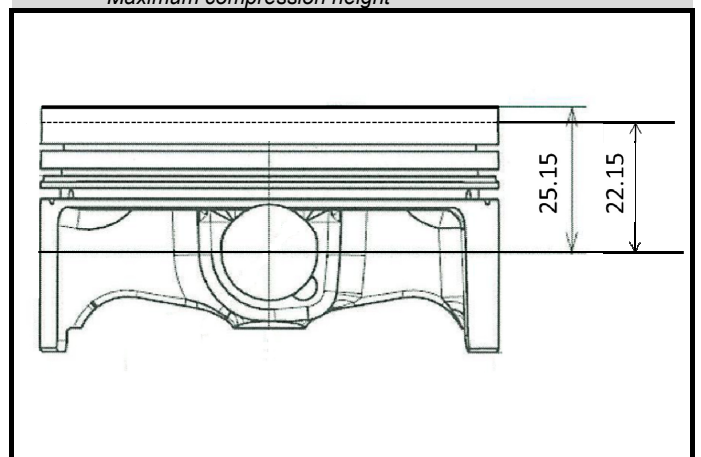

318. BIELLE / CONNECTING ROD

a) Matériau Material	Acier Steel	b) Type de la tête de bielle Big end type	Séparée Split
c) Diamètre intérieur de la tête de bielle (sans coussinets) Interior diameter of the big end (without shell bearings)	37.0	+0.1 - 0 mm	
d) Longueur entre axes Length between axes	124.0	± 0.1 mm	e) Poids minimum Minimum weight
			343
			g

C5-1) Bielle de $\frac{3}{4}$ côté tête
Connecting rod from $\frac{3}{4}$ on big end side

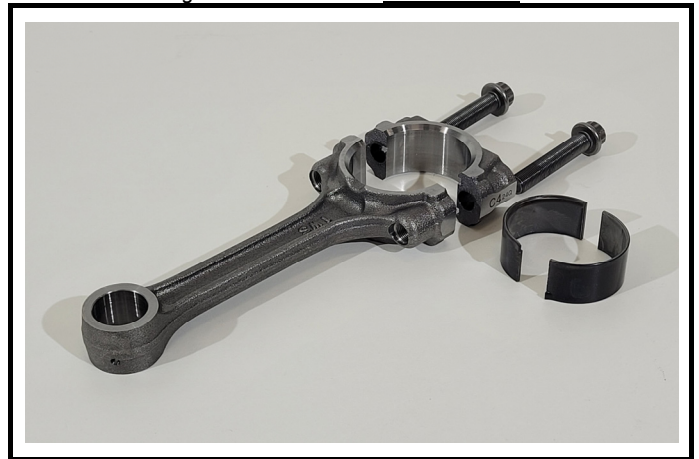

C5-2) Bielle de $\frac{3}{4}$ arrière côté pied
Connecting rod from $\frac{3}{4}$ rear on small end side

**319. VILEBREQUIN / CRANKSHAFT**

a) Type de construction Type of manufacture	Deux / Two pieces	b) Matériau Material	Acier Steel
c) Procédé de fabrication Manufacturing process	Coulé Cast <input type="checkbox"/>	Forgé Forged <input checked="" type="checkbox"/>	Usiné dans la masse Machined from raw <input type="checkbox"/>
f) Diamètre des tourillons Diameter of main journals	34	+0 - 0.1 mm	
g) Matériau des chapeaux de paliers Bearing caps material	Aluminium		
h) Poids minimum du vilebrequin Minimum weight of crankshaft	7868	g	
i) Diamètre des manetons Diameter of crank pins	34	+0 - 0.1 mm	

C6-1) Vilebrequin de $\frac{3}{4}$ avant
Crankshaft from $\frac{3}{4}$ front

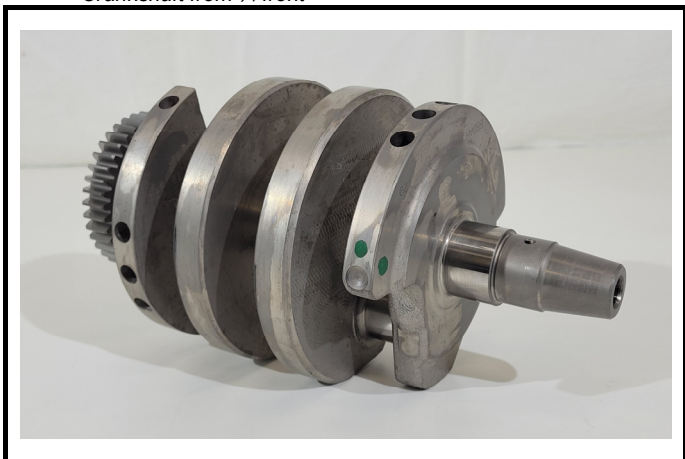

C6-2) Vilebrequin de $\frac{3}{4}$ arrière
Crankshaft from $\frac{3}{4}$ rear



321. CULASSE / CYLINDERHEAD

- b) Matériau
Material
- c) Hauteur minimum
Minimum height
- d) Endroit de la mesure
Where measured
- g) Volume minimum d'une chambre de combustion
Minimum volume of a combustion chamber

Aluminium**105.9** mm**From cam cap face to fire face****31** cm³ (Incl. Piston et Joint de culasse
Incl. Piston and Cyl. Head Gasket)

C8-1) Culasse nue vue de dessus (côté arbres à cames)
Bare cylinderhead seen from top (camshaft side)

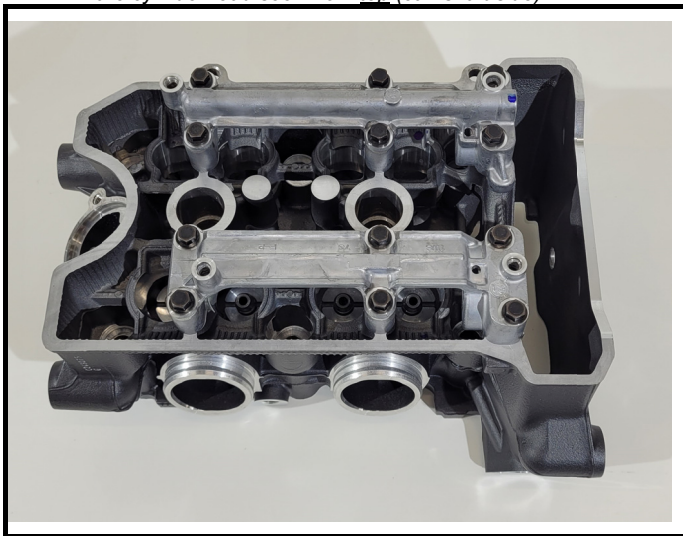

C8-2) Culasse nue vue de dessous (côté chambre)
Bare cylinderhead seen from underneath (chamber side)



C8-3) Culasse nue vue côté admission
Bare cylinderhead seen from intake side



C8-4) Culasse nue vue côté échappement
Bare cylinderhead seen from exhaust side



C8-5) Culasse nue vue côté gauche
Bare cylinderhead seen from left hand side



C8-6) Culasse nue vue côté droit
Bare cylinderhead seen from right hand side



C8-7) Chambre de combustion
Combustion chamber



III-E1) Diamètre maximum au niveau du siège admission
Maximum intake seat diameter

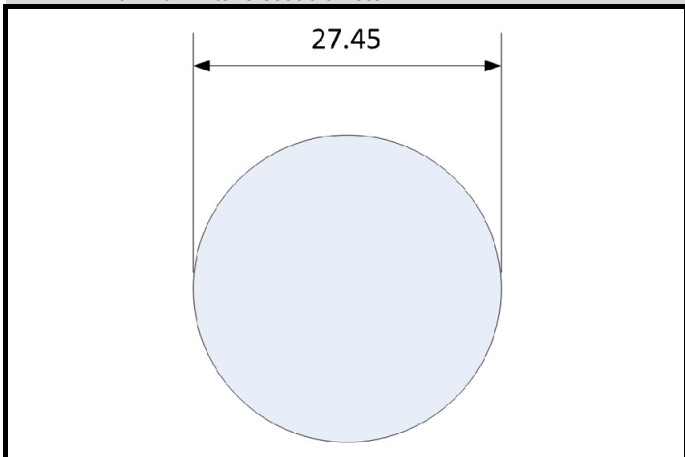

III-E2) Diamètre maximum au niveau du siège échappement
Maximum exhaust seat diameter

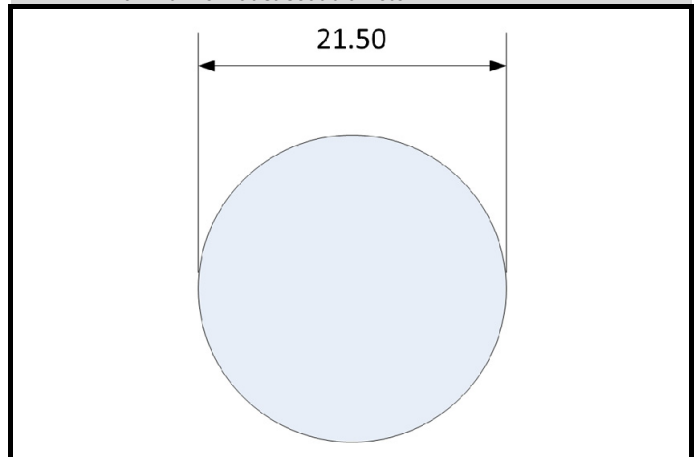

ADMISSION / INTAKE

Dessins des orifices de la culasse - tolérances sur les dimensions : $-2/+4$ %
Drawings of cylinder head ports - tolerances on dimensions : $-2/+4$ %

III-K1) Culasse, face collecteur / Cylinderhead, manifold side

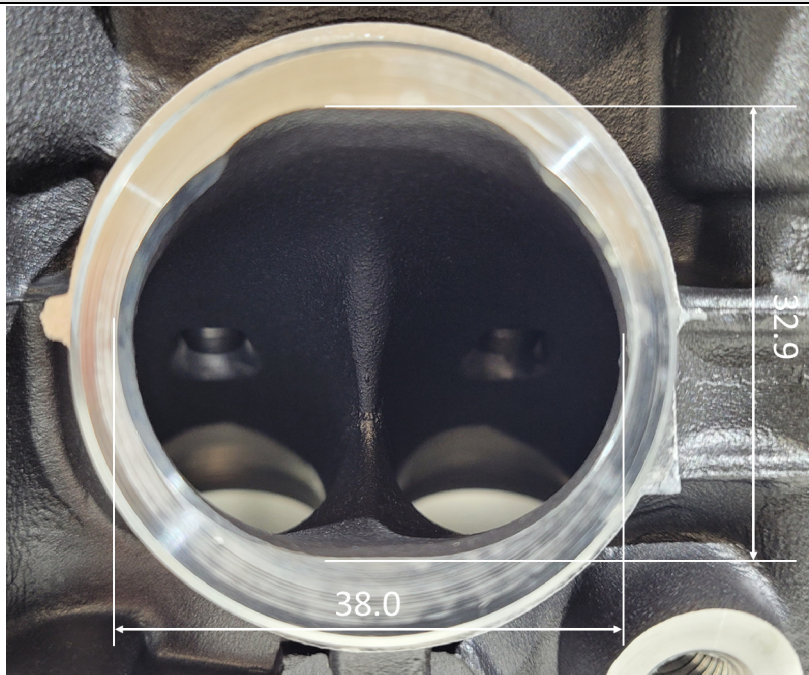
**ECHAPPEMENT / EXHAUST**

Dessins des orifices de la culasse - tolérances sur les dimensions : $-2/+4$ %
Drawings of cylinder head ports - tolerances on dimensions : $-2/+4$ %

III-L1) Culasse, face collecteur / Cylinderhead, manifold side

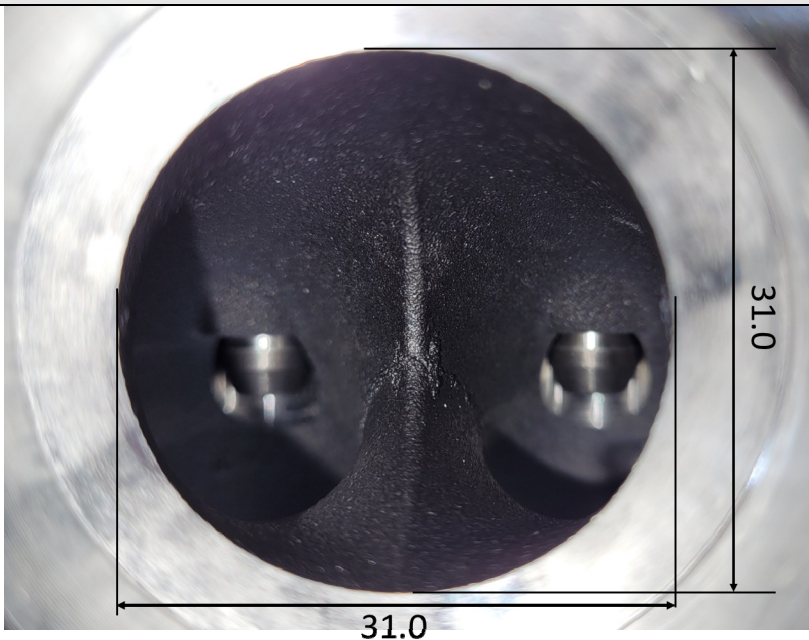

322. JOINT DE CULASSE / CYLINDERHEAD GASKET

- a) Epaisseur du joint de culasse serré
Thickness of tightened cylinderhead gasket **0.6** ± 0.1 mm
- b) Endroit de mesure
Location of measurement **Côté admission, moteur monté / On intake side, engine assembled**

C8-14) Joint de culasse – déposé
Cylinderhead gasket – dismantled

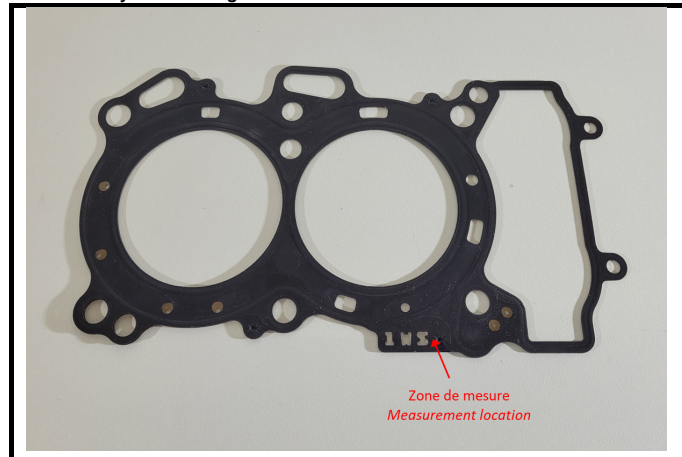
**324. ALIMENTATION PAR INJECTION - ELECTRONIQUE / FUEL FEED BY INJECTION - ELECTRONICS**

- a) Référence injecteurs bas
Low Injectors référence **1WS-13761-00**
- b) Référence injecteurs haut
High Injectors référence Not applicable

C9-1) Injecteurs bas
Low Injectors low



C9-2) Nozzle Injecteurs bas
Low Injectors Nozzle

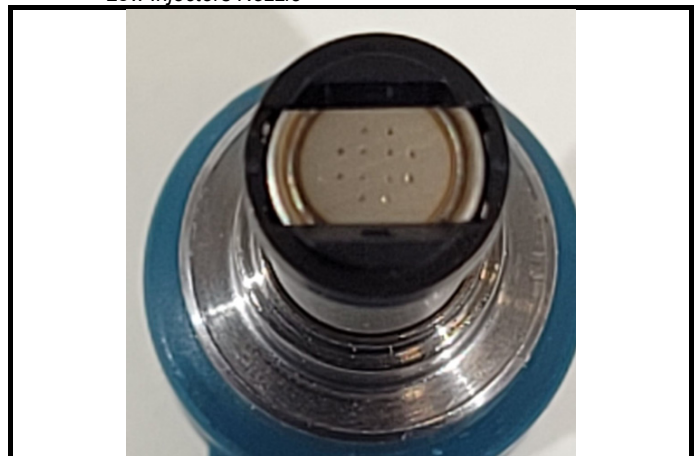

C9-1) Injecteurs haut
High *Injectors*

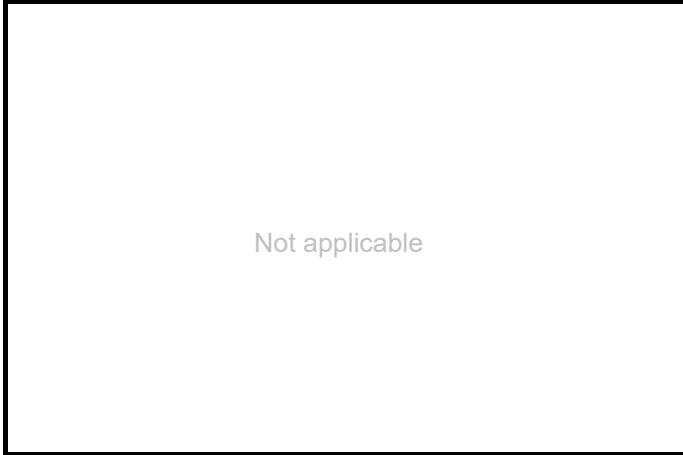

C9-2) Nozzle Injecteurs haut
High *Injectors Nozzle*

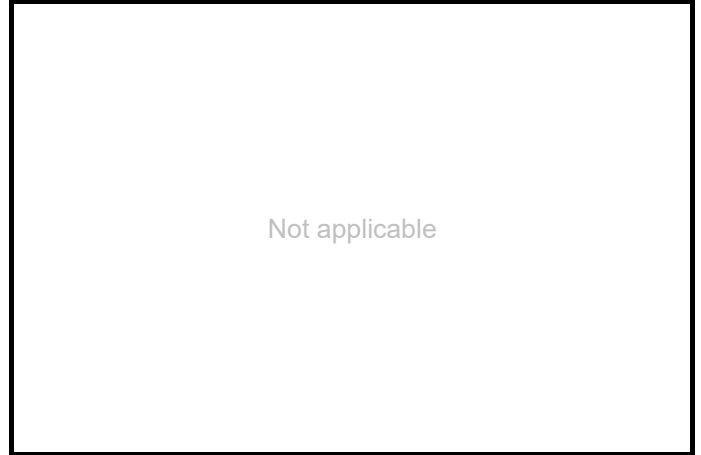

324. SYSTEME DE CONTROLE MOTEUR / ENGINE CONTROL SYSTEM

- a) Marque et type **DENSO** Injection - Direct Injection - Indirect
Make and type
- Mécanique / *Mechanical* Electronique / *Electronic* Hydraulique / *Hydraulic*
- c) Dosage du carburant
Fuel measurement
- e) Nombre de sorties effectives de carburant **4**
Number of effective fuel outlets
- f) Injecteurs f1) Position Collecteur / *Manifold* Culasse / *Cylinder head*
Injectors Position
 Chambre *Chamber* Pré-chambre *Pre-chamber*
- g) Liste des capteurs du système de contrôle moteur
List of engine control system sensors

N°	Number	Function	Make & Reference
C1	x1	GEARBOX POSITION	1WS8254000
C2	x1	THROTTLE POSITION	3B4-85885-01
C3	x1	AIR CHARGE PRESSURE	1WS8238000
C4	x1	ENGINE SPEED	1WS8141000
C5	x1	WATER TEMP	4P98359100
C6	x1	AIR TEMP	5YU8588600
C7	x1	LAMBDA	1WS 8592A 1000 or B4T-8592A-00
C8	x1	BAROMETRIC PRESSURE	Not applicable
C9	x1	ACCELERATOR SENSOR	Not applicable

- h) Liste des actuateurs du système de contrôle moteur
List of engine control system actuators

N°	Number	Function	Make & Reference
A1	x1	ELECTRICAL THROTTLE	Not applicable
A2	x2	COILS	mitsubishi / 1WS8231000
A3	x1	FUEL INJECTORS LOW	1WS-13761-00
A4	x1	ENGINE CONTROL UNIT	DENSO XXX-8591A-YYY
A5	x1	IDLE VALVE	1WS-85801-00

C9-1) Système de contrôle moteur
Engine control system

 C1	 C2	 C3	 C4
 C5	 C6	 C7	 C8
 C9	 C10	 C11	 C12
 C13	 C14	 C15	 C16
 A1	 A2	 A3	 A4
 A4	 A5	 A6	 A7

III-II) LOCALISATION DES CAPTEURS ET ACTIONNEURS / LOCATION OF SENSORS AND ACTUATORS

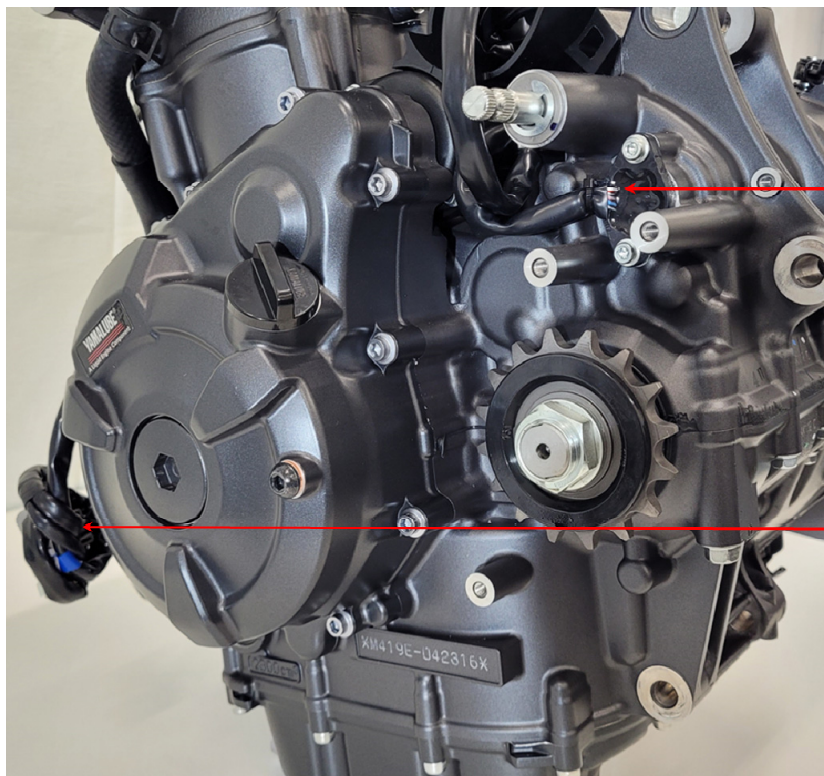
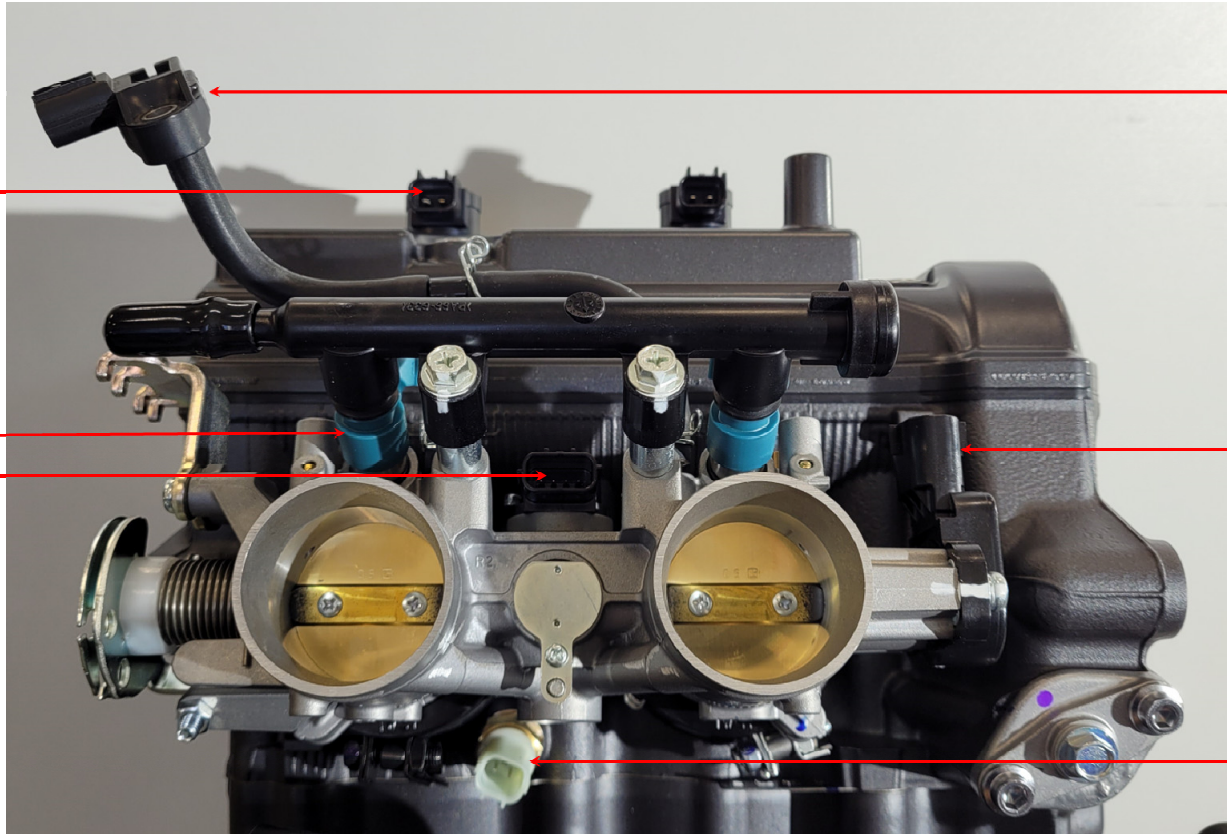

325. ARBRE A CAMES / CAMSHAFT

c) Système d'entraînement
Drive system

Chain

e) Diamètre des tourillons
Diameter of journals

21.96 ± 0.1 mm

g) Dimensions de la came
Cam dimensions

	Admission Intake	Echappement Exhaust
A =	28.0 ± 0.1 mm	27.98 ± 0.1 mm
B =	35.65 ± 0.1 mm	35.73 ± 0.1 mm

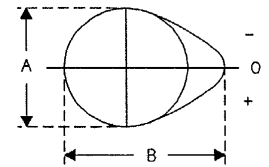

Les tolérances s'appliquent avec le même signe pour A et B
The tolerances must be used with the same sign for A and B

h) Poids minimum (nu)
Minimum weight (bare)

0.512 kg	0.510 kg
-----------------	-----------------

326. DISTRIBUTION / TIMING

a) Jeu théorique mini
Min Theoretical clearance

Admission Intake **0.10** mm

Echappement Exhaust **0.24** mm

b) Calage sommet de came
Cam timing (in crank angle)

Admission Intake **111** ± 2°

Echappement Exhaust **112** ± 2°

c) Levée de came en mm (arbre déposé)
Cam lift in mm (dismounted camshaft)

Mesuré avec bille de 3 mm de diamètre
Measured with a 3mm diameter ball

ADMISSION / INTAKE				ECHAPPEMENT / EXHAUST			
Angle de Rotation en degrés Rotation angle in degrees	Levée en mm Lift in mm (± 0.05 mm)	Angle de rotation en degrés Rotation angle in degrees	Levée en mm Lift in mm (± 0.05 mm)	Angle de rotation en degrés Rotation angle in degrees	Levée en mm Lift in mm (± 0.05 mm)	Angle de rotation en degrés Rotation angle in degrees	Levée en mm Lift in mm (± 0.05 mm)
0	7.66			0	7.76		
- 5	7.33	+ 5	7.40	- 5	7.56	+ 5	7.49
- 10	6.50	+ 10	6.59	- 10	6.83	+ 10	6.78
- 15	5.29	+ 15	5.42	- 15	5.67	+ 15	5.60
- 20	4.15	+ 20	4.30	- 20	4.45	+ 20	4.44
- 25	3.20	+ 25	3.29	- 25	3.48	+ 25	3.40
- 30	2.39	+ 30	2.47	- 30	2.66	+ 30	2.58
- 35	1.73	+ 35	1.81	- 35	1.98	+ 35	1.89
- 40	1.22	+ 40	1.26	- 40	1.43	+ 40	1.36
- 45	0.83	+ 45	0.86	- 45	1.01	+ 45	0.95
- 50	0.55	+ 50	0.58	- 50	0.70	+ 50	0.66
- 55	0.38	+ 55	0.39	- 55	0.50	+ 55	0.48
- 60	0.27	+ 60	0.28	- 60	0.39	+ 60	0.37
- 65	0.20	+ 65	0.21	- 65	0.31	+ 65	0.30
- 70	0.13	+ 70	0.14	- 70	0.23	+ 70	0.22
- 75	0.07	+ 75	0.07	- 75	0.16	+ 75	0.15
- 80	0.00	+ 80	0.01	- 80	0.09	+ 80	0.07
- 85	0.00	+ 85	0.00	- 85	0.01	+ 85	0.01
- 90	0.00	+ 90	0.00	- 90	0.00	+ 90	0.00

Un décalage de l'ensemble des mesures de +/- 2 degrés est accepté / + = Sens de rotation identique au moteur
A shift of +/- 2 degrees of the whole measurement is accepted / + = Same rotation direction as engine

c) Levée maximum des soupapes
Maximum valve lift

Admission Intake	Echappement Exhaust
7.6	7.6

avec jeu selon Art. 326a
with clearance according to Art. 326a

C10-1) Arbres à cames - déposé
Camshaft - dismounted

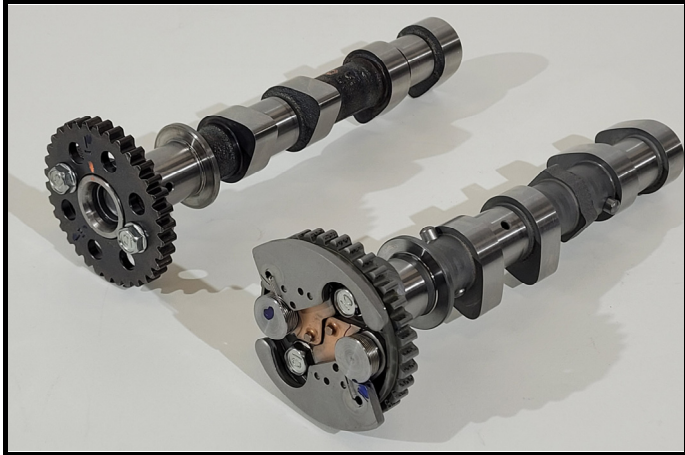

C10-2) Arbres à cames - déposé
Camshaft - dismounted



C10-5) Pignons arbres à cames- démontés
Camshafts gears - dismounted

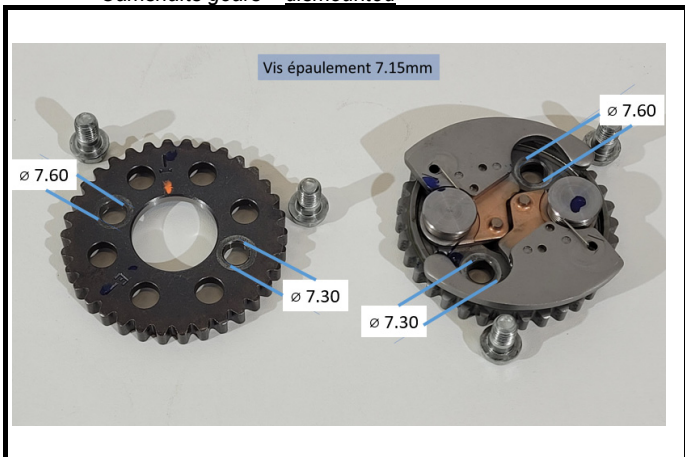

III-J2) Culbuteur - dimensions caractéristiques
Rocker arm - typical dimensions

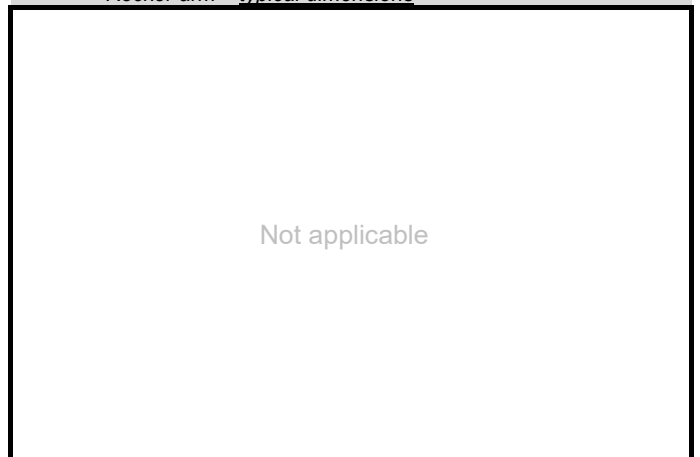

C10-6) Poussoir Admission - démonté
Tappet Intake - dismounted



III-J3) Poussoir Admission - dimensions caractéristiques
Tappet Intake - typical dimensions

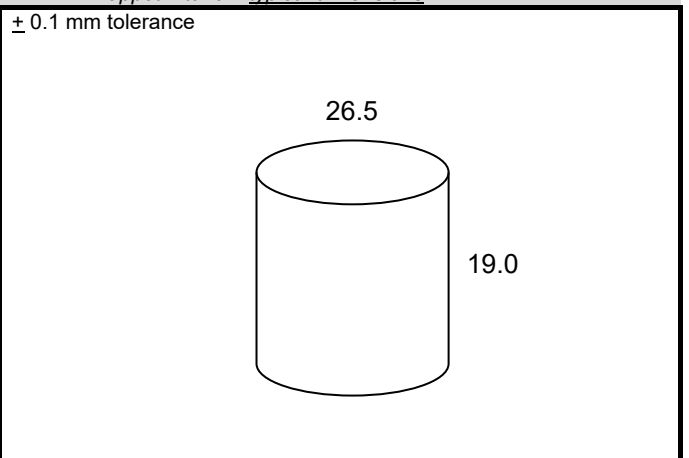

C10-7) Poussoir Echappement – démonté
Tappet Exhaust – dismounted



III-J4) Poussoir Echappement – dimensions caractéristiques
Tappet Exhaust – typical dimensions

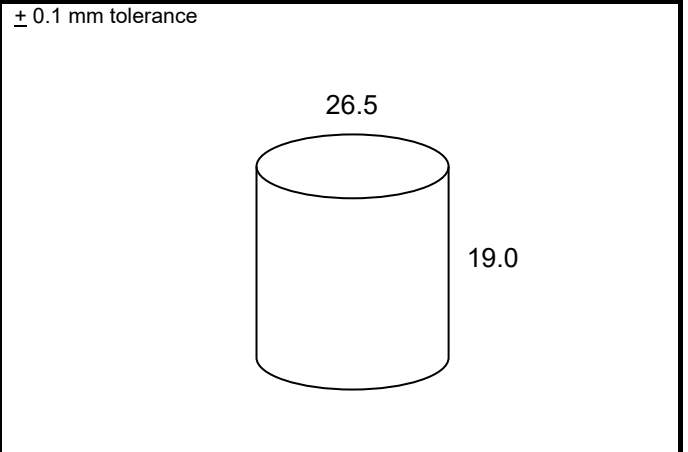

C10-8) Ressort soupape admission
Intake valve spring



C10-9) Ressort soupape échappement
Exhaust valve spring



- d) Long. ressort soupape adm. libre
Intake valve spring free length **40.15** ± 1 mm
- e) Long. ressort soupape adm. sous 200 Nm
Intake valve spring length under 200 Nm **33.20** ± 1 mm
- g) Diamètre fil ressort soupape adm.
Intake valve spring wire diameter **3.7 x 2.9** ± 0.1 mm

- d) Long. ressort soupape éch. libre
Exhaust valve spring free length **41.10** ± 1 mm
- f) Long. ressort soupape échap. sous 200 Nm
Exhaust valve spring length under 200 Nm **35.0** ± 1 mm
- h) Diamètre fil ressort soupape échap.
Exhaust valve spring wire diameter **3.9 x 3.1** ± 0.1 mm

C10-10) Courroie, chaîne ou Pignons de distribution – déposée(s)
Timing belt, chain or gears – dismounted

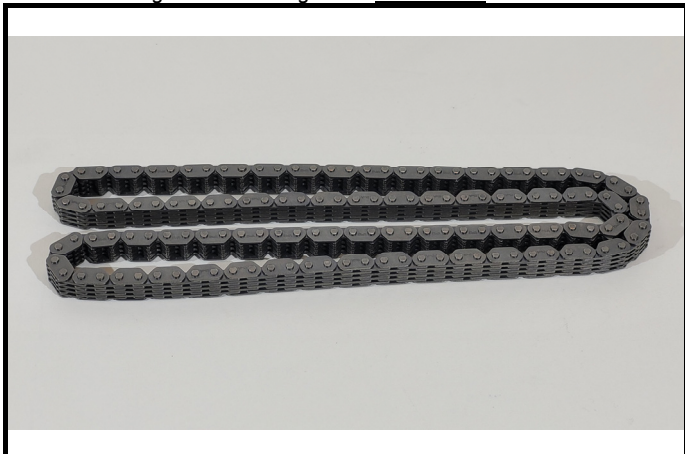

Type / Type : **Silent Chain**

Pas / Pitch : **6.35** ± 0.1 mm

Nb de dents / Nb of teeth : **67**

Longueur / Length : **850** ± 2 mm (extérieur/outside)

Largeur / Width : **8.9** ± 0.1 mm

327. ADMISSION / INTAKE

a) Matériau des trompettes <i>Material of trumpets</i>	N/A				
b) Dimensions du conduit d'admission au niveau du papillon <i>Dimensions of the intake pipe at the throttle valve</i>	38.0			+0.1 / -0.2 mm	
c) Distance entre tôle papillons et culasse min / max <i>Distance between throttle valve and head min / max</i>	44.5 / 48.0			± 2 mm	
d) Diamètre max. de tête de soupape <i>Maximum diameter of the valve head</i>	31.5		± 0.1 mm	d1) Angle de la tête de soupape <i>Angle of valve head</i>	45.0 deg ± 30 min
e) Diamètre tige de soupape <i>Diameter of valve stem</i>	4.5		+0 -0.2 mm	f) Longueur de soupape <i>Valve length</i>	86.3 ± 1.5 mm
g) Matière soupape <i>Valve material</i>	Acier Steel			h) Masse soupape mini <i>Min valve weight</i>	29.3 g
i) Matière coupelle ressort <i>Spring plate material</i>	Acier Steel			j) Masse coupelle ressort min <i>Min spring plate weight</i>	7.8 g

C11-1) Boite à air - déposé
airbox - dismounted



C11-2) boite à air - déposé
airbox - dismounted



C11-3) Boitier papillon - déposé
Throttle unit - dismounted

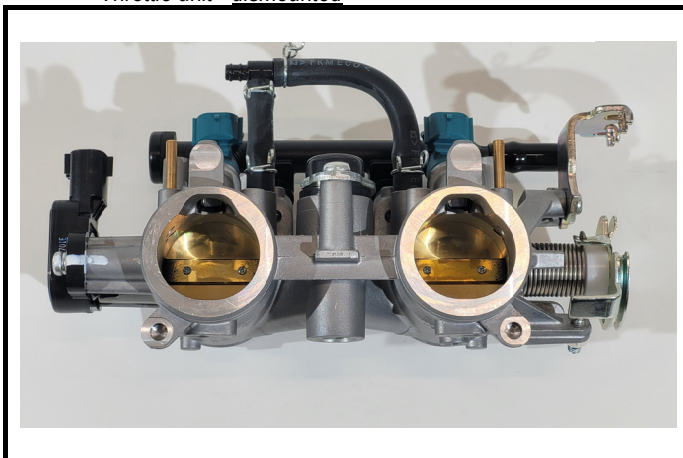

C11-4) Boitier papillon - déposé
Throttle unit - dismounted



C11-5) Soupape admission - déposée
Intake valve - dismantled



C11-6) Coupelle de ressort admission - déposée
Intake spring plate - dismantled



328. ECHAPPEMENT / EXHAUST

d) Diamètre maximum de soupape Maximum diameter of the valve	26.5	± 0.1 mm	d1) Angle de la tête de soupape Angle of valve head	45.0	deg ± 30 min
e) Diamètre tige de soupape Diameter of valve stem	4.5	+0 / -0.2 mm	f) Longueur de soupape Valve length	86.3	± 1.5 mm
g) Matière soupape Valve material	Acier / Inox Steel / Stainless		h) Masse soupape mini Min valve weight	25.2	g
i) Matière coupelle ressort Spring plate material	Acier Steel		j) Masse coupelle ressort mini Min spring plate weight	7.8	g

C12-1) Soupape échappement - déposée
Exhaust valve - dismantled



C12-2) Coupelle de ressort échappement - déposée
Exhaust spring plate - dismantled



ECHAPPEMENT / EXHAUST

Dessin de l'échappement complet
Drawing of the complete exhaust

III-L1) Echappement / Exhaust

All dimensions in mm

All diameters are internal diameters

Not applicable

SILENCIEUX / SILENCER

Dessin du silencieux complet
Drawing of the complete silencer

III-L3) Silencieux / Silencer

All dimensions in mm

All diameters are internal diameters

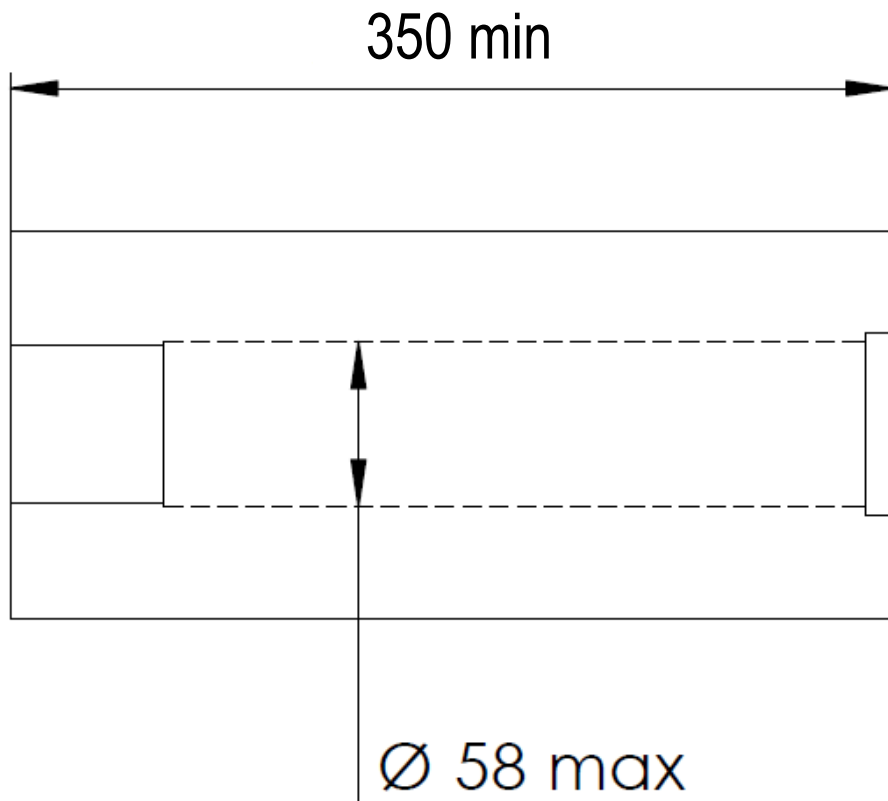

SECTION OF SILENCER

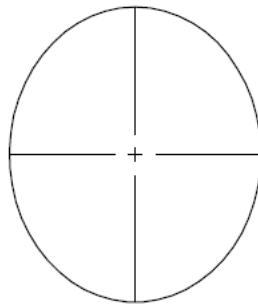

Free shape with
 Min surface of 125 cm²

331. SYSTEME DE REFROIDISSEMENT / COOLING SYSTEM

c) Type de la pompe à eau
Origin of the water pump

Mechanical

C13-3) Pompe à eau - déposée
Water pump - dismantled



C13-4) Pompe à eau montée sur le moteur
Water pump mounted on engine



C13-5) Roue de turbine de pompe à eau
Turbine wheel of water pump



III-M2) Roue de turbine de pompe à eau
Turbine wheel of water pump

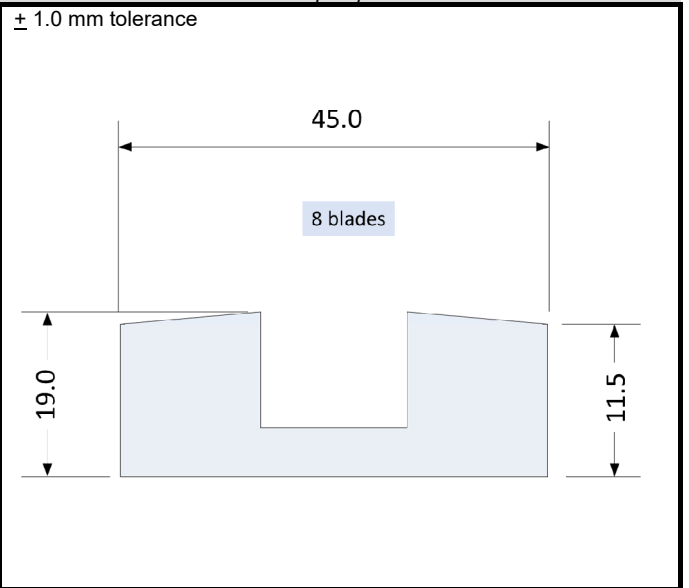

333. SYSTEME DE LUBRIFICATION / LUBRICATION SYSTEM

- a) Matériau du carter d'huile
Material of oil sump

Aluminium

C14-1) Carter d'huile - déposé
Oil sump - dismounted



C14-2) Carter d'huile - déposé
Oil sump - dismounted



C14-3) Pompe à huile - déposée
Oil pump - dismounted



C14-3b) Pompe à huile - déposée
Oil pump - dismounted

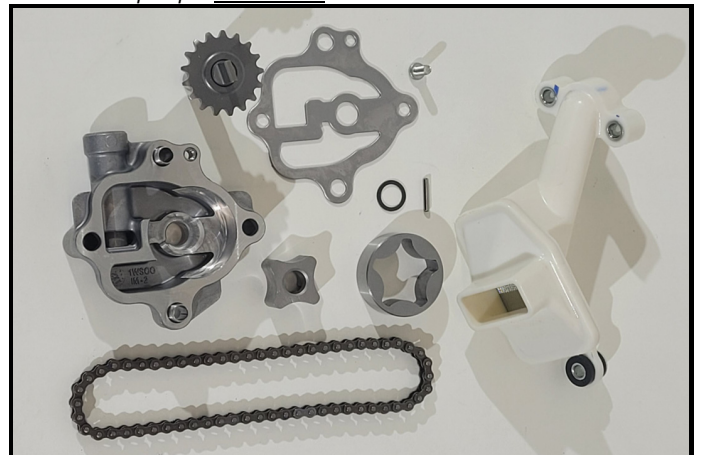

C14-4) Pompe à huile - montée dans son emplacement
Oil pump - mounted in its location

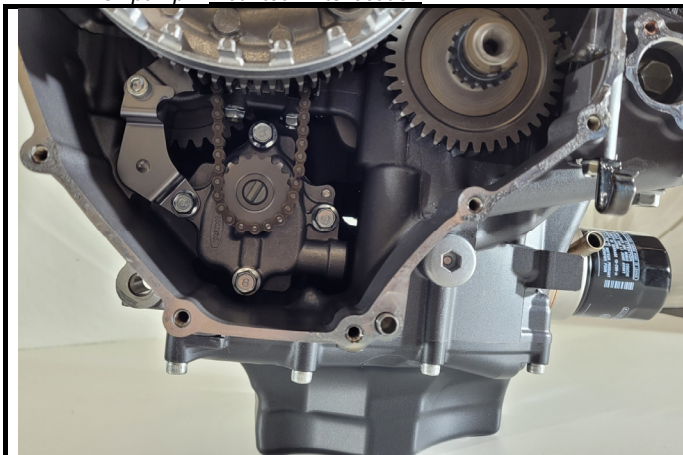

4. ESSENCE / FUEL

402. POMPE A CARBURANT / FUEL PUMP

a) Pressure maximale Max fuel pressure	3.9	barA
---	------------	------

5. EQUIPEMENT ELECTRIQUE / ELECTRICAL EQUIPMENT

502. ALTERNATEUR / GENERATEUR / DEMARREUR / ALTERNATOR / GENERATOR / STARTER

a) Diamètre extérieur Rotor <i>Rotor External diameter</i>	137.5	+/- 0.5 mm
b) Diamètre intérieur Rotor <i>Rotor Internal diameter</i>	116.5	+/- 0.5 mm
c) Nombre de pôles du Rotor <i>Number of Rotor pôles</i>	18	
d) Largeur des pôles du Rotor <i>Width of Rotor pôles</i>	15.3	+/- 0.5 mm
e) Diamètre extérieur du Stator <i>Stator external diameter</i>	114	+/- 0.5 mm
f) Diamètre intérieur du Stator <i>Stator internal diameter</i>	54	+/- 0.5 mm

C15-1) Rotor - déposé
Rotor - dismantled



C15-2) Stator - déposé
Stator - dismantled

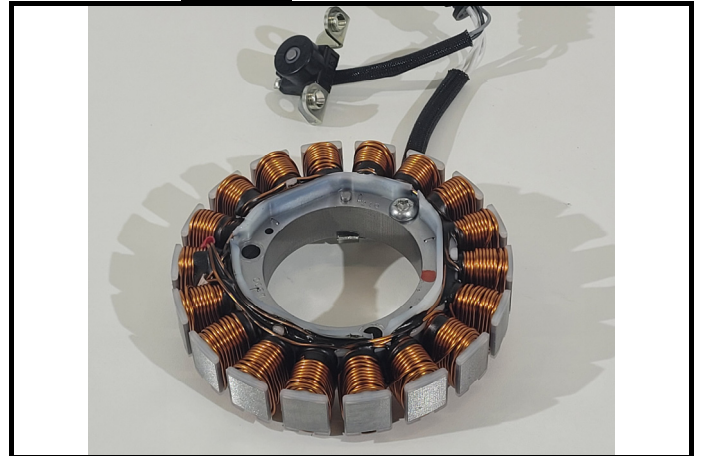

504. DÉMARREUR / STARTER

a) Référence démarreur: <i>Starter reference:</i>	1WS-81890-00	
a) Roue libre: Nb de dents <i>Free wheel : Teeth nb :</i>	66	
b) Largeur de la roue libre : <i>Free wheel width :</i>	7.6	+/- 0.5 mm

C16-1) Démarreur - déposé
Starter - dismantled



C16-2) Roue libre - déposée
Free Wheel - dismantled

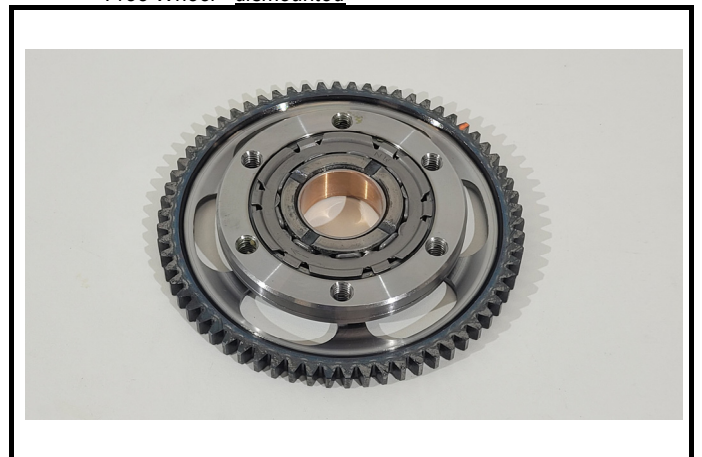

6. TRANSMISSION / POWER TRAIN

602. EMBRAYAGE / CLUTCH

a) Masse ensemble Assembly weight	3543		g		+/- 50 g
b) Disques Menants Driving disks	a1) Nombre Number	7 frités	a2) Epaisseur Thickness	3.0	+/- 0.5mm
c) Disques Menés Driven disks	b1) Nombre Number	6 lisses	b2) Epaisseur Thickness	2.0	+/- 0.5mm

C17-1) Embrayage complet - monté
Complete Clutch - mounted

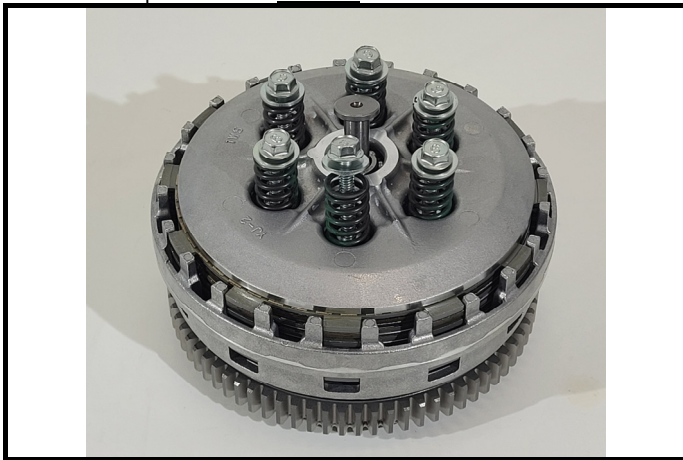

C17-2) Disque menant - déposé
Driving disk - dismounted

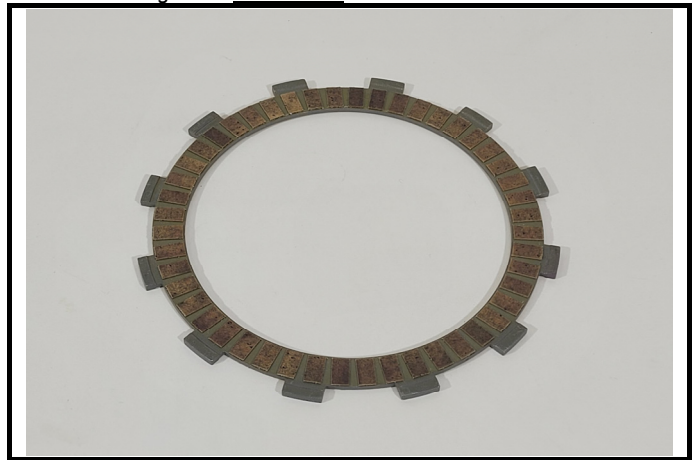

C17-3) Disque mené - déposé
Driven disk - dismounted

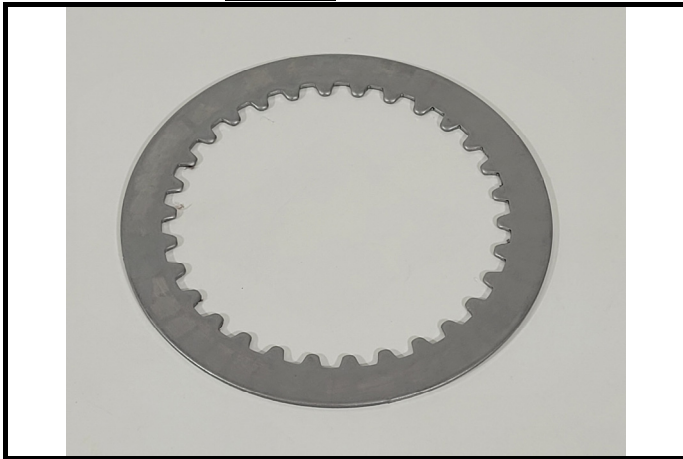

C17-4) Ressort
Spring



602 EMBRAYAGE / CLUTCH / ANTI DRIBLEd) Rondelles ressorts
*Spring washer*a1) *Nombre*
Number

Not applicable

a2) *Epaisseur*
Thickness

Not applicable

+/- 0.1mm

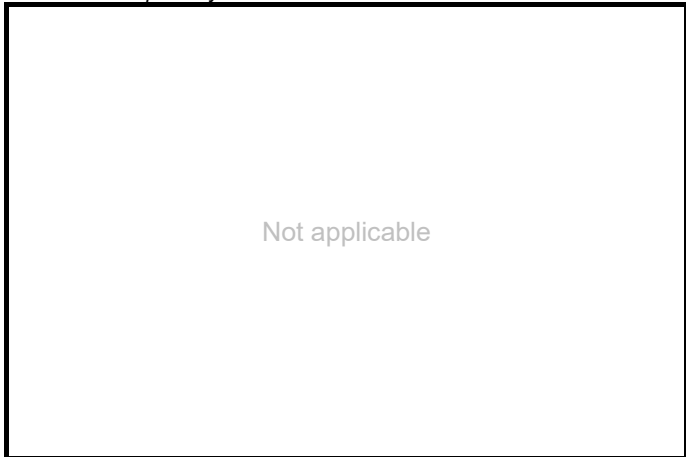
C17-5) Système complet
Complete system

Not applicable

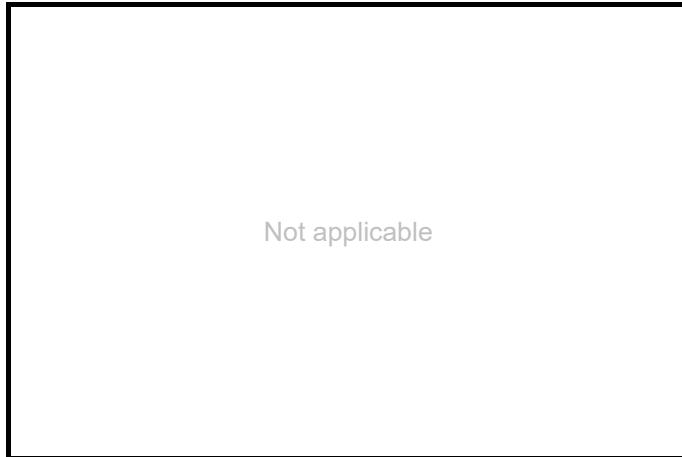
C17-6) Came pour pilotage embrayage
Cam for clutch drive

Not applicable

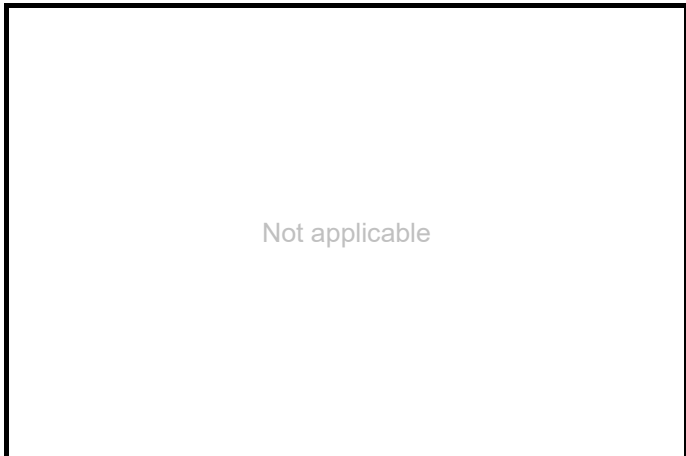
C17-7) Came d'embrayage – vue de face
Clutch cam – face view

Not applicable

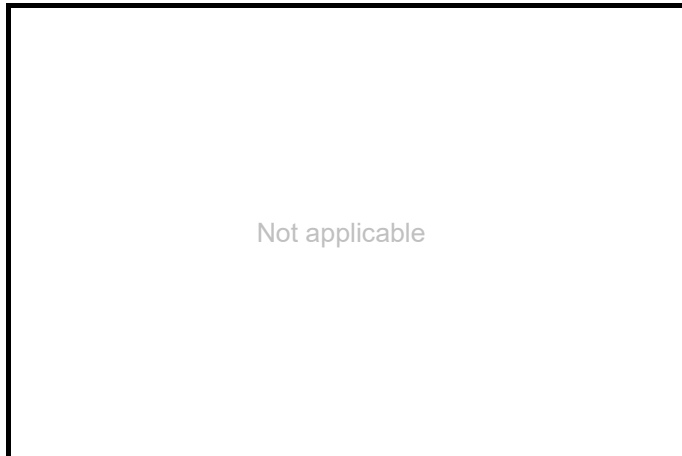
C17-8) Came d'embrayage - vue de dos
Clutch cam – rear view

Not applicable

603. BOITE DE VITESSES / GEARBOX

a) Emplacement:
Location: **Carter moteur**
Engine Block

b) Rapp. Primaire sur Vilebrequin:
Primary ratio on crankshaft **40**

c) Rapp. Primaire sur Embrayage:
Primary ratio on clutch **77**

	d) Primaire: Layshaft:	e) Secondaire: Pinionshaft:	f) Matériau: Material:	g) Epaisseurs (mm): Thicknesses (mm): + 0.5mm	h) Masse (g): Weight (g): + 15 g
No. 1	13	37	Acier / Acier	21.5 / 13.7	685 / 356
No. 2	16	34	Acier / Acier	14.1 / 14	110 / 304
No. 3	19	31	Acier / Acier	12.7 / 12.9	371 / 255
No. 4	20	26	Acier / Acier	11.1 / 11.4	371 / 200
No. 5	22	24	Acier / Acier	13.1 / 13.2	247 / 412
No. 6	28	27	Acier / Acier	14.6 / 14.6	254 / 370

F12-1) Gear Crankshaft



F12-2) Gear Clutch



F12-3) Gear No. 1 front view

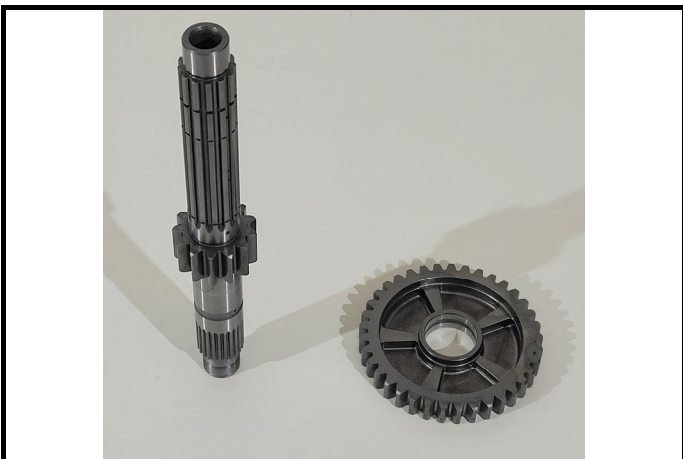

F12-4) Gear No. 1 rear view

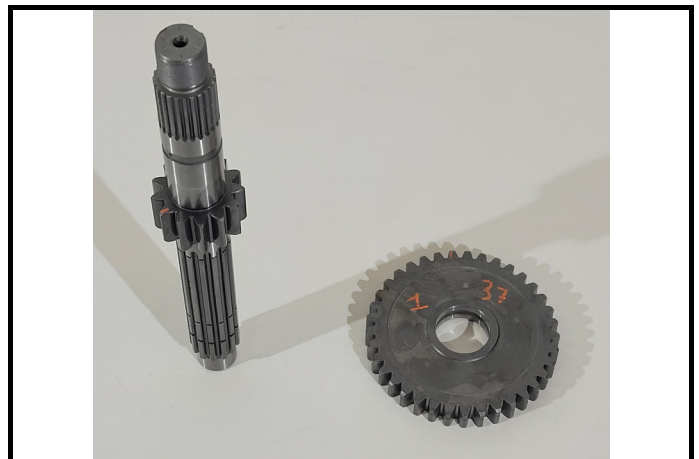

F12-5) Gear No. 2 front view

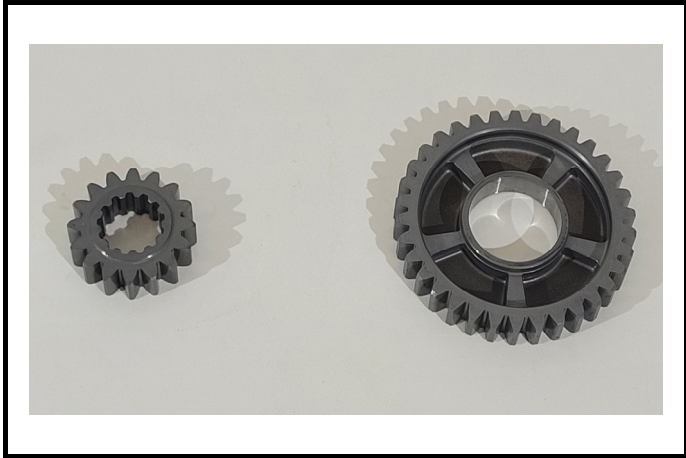

F12-6) Gear No. 2 rear view

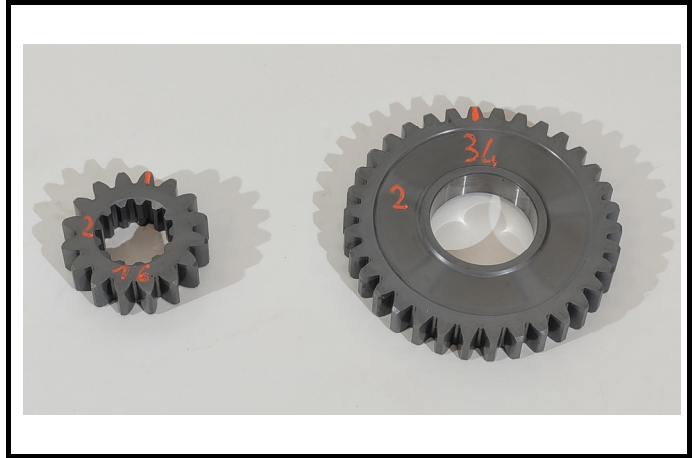

F12-7) Gear No. 3 front view

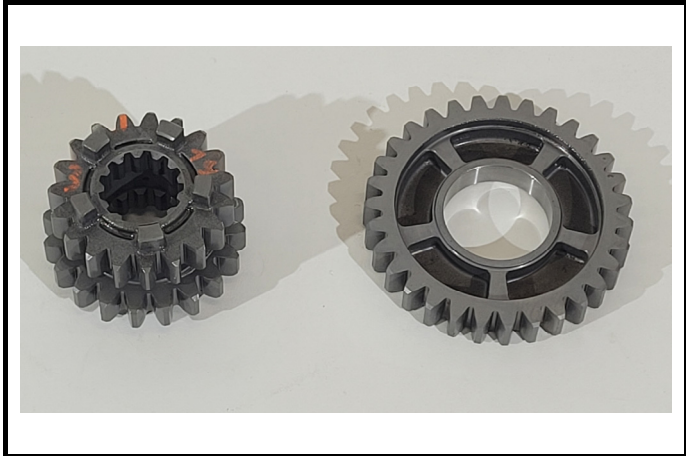

F12-8) Gear No. 3 rear view

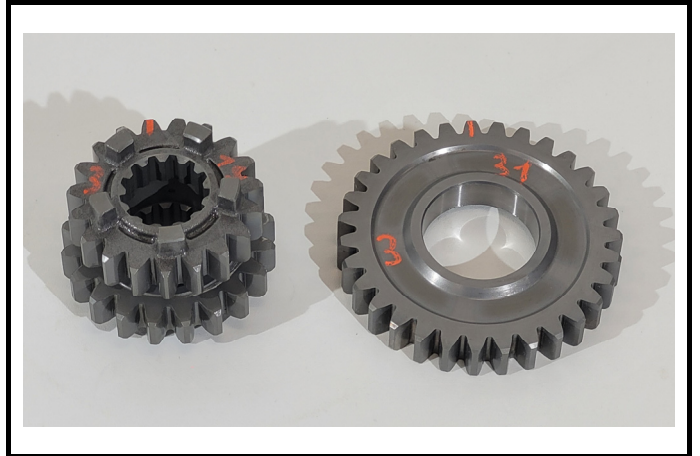

F12-9) Gear No. 4 front view

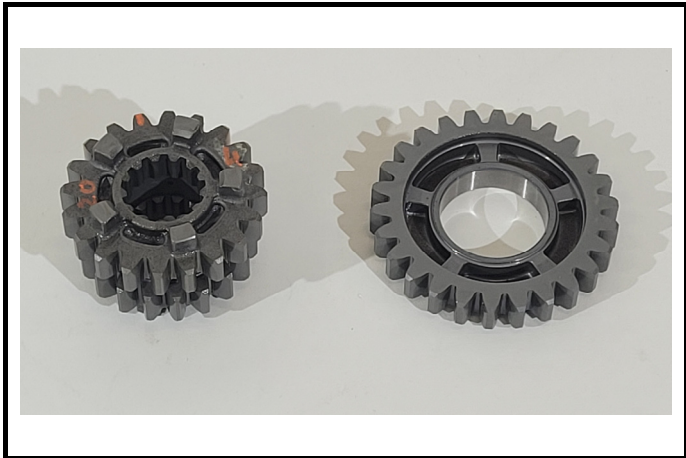

F12-10) Gear No. 4 rear view

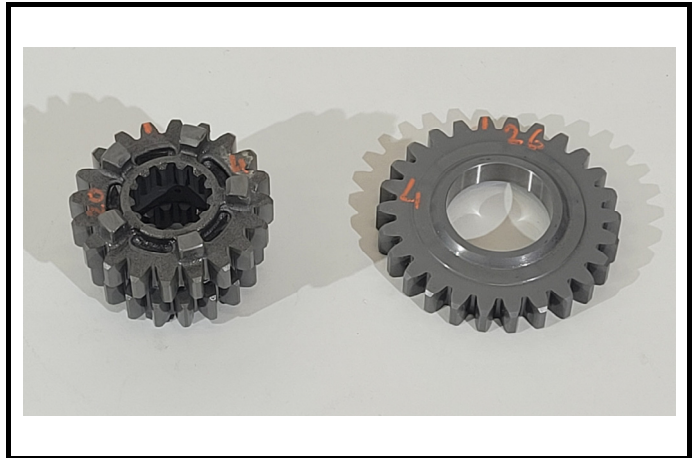

F12-11) Gear No. 5 front view



F12-12) Gear No. 5 rear view



F12-13) Gear No. 6 front view

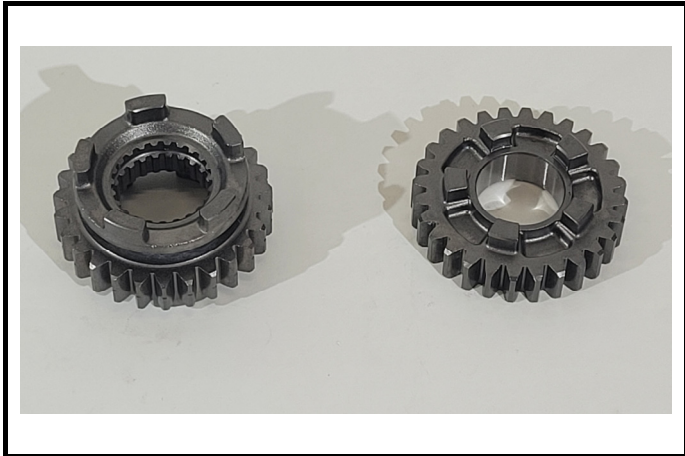

F12-14) Gear No. 6 rear view



604. ASSEMBLAGE ARBRE PRIMAIRE / LAYSHAFT ASSEMBLY

a) Référence du Roulement Reference of bearing	9330620464	
b) Masse du Roulement Weight of bearing	336	± 10 g
c) Largeur / Diamètres intérieurs et extérieurs du Roulement Width / External and internal diameters of bearing	17 – 25 -- 62	± 0.1 mm
d) Masse de l'Arbre primaire Weight of layshaft	686	± 10 g
e) Matériau de l'Arbre primaire Material of layshaft	Acier / Steel	

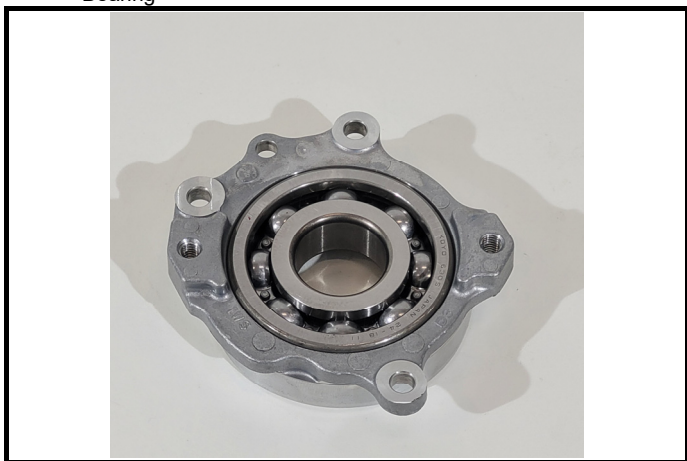
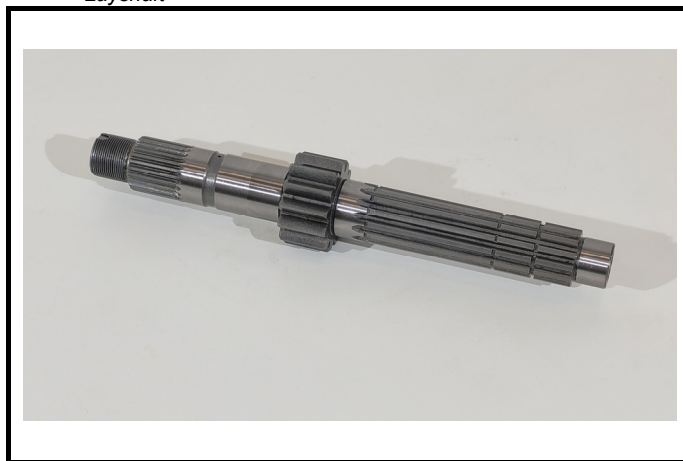
F7-1) Roulement
BearingF7-2) Arbre primaire
Layshaft

605. ASSEMBLAGE ARBRE SECONDAIRE / PINIONSHAFT / MAINSHAFT ASSEMBLY

a) Matériau de l'Arbre secondaire <i>Material of pinionshaft/mainshaft</i>	Acier / Steel	
b) Masse de l'Arbre secondaire <i>Weight of pinionshaft/mainshaft</i>	871	± 10 g
c) Référence du Roulement gauche <i>Reference of left mainshaft bearing</i>	9330620464	
d) Largeur / Diamètres intérieurs et extérieurs du Roulement gauche <i>Width / External and internal diameters of mainshaft bearing</i>	14 – 20 – 47	± 0.1 mm
e) Masse du Roulement gauche <i>Weight of left mainshaft bearing</i>	100	± 10 g
f) Référence du Roulement droit <i>Reference of right mainshaft bearing</i>	9330620663	
g) Largeur / Diamètres intérieurs et extérieurs du Roulement droite <i>Width / External and internal diameters of right mainshaft bearing</i>	16– 30 -- 66	± 0.1 mm
h) Masse du Roulement droit (avec support et clips) <i>Weight of right mainshaft bearing (With support and clips)</i>	255	± 10 g
i) Largeur / Diamètres intérieurs et extérieurs du Roulement à aiguilles des rapports <i>Width / External and internal diameters of ratio needle bearings</i>	Not applicable	± 0.1 mm
j) Masse du Roulement à aiguilles des rapports <i>Weight of ratio needle bearings</i>	Not applicable	± 5 g
k) Référence du Roulement Aiguille <i>Material of the hub</i>	Not applicable	
l) Nombre de crabot sur chaque pignon <i>Number of dog on each gear</i>	1 : 5 / 2 : 5 / 3 : 5 / 4 : 5 / 5 : 5 / 6 : 5	
m) Matériau des anneaux de crabotage <i>Material of clutch rings</i>	Acier intégré aux pignons Steel integrated in gears	
n) Masse des anneaux de crabotage <i>Weight of clutch rings</i>	Intégré aux pignons Integrated to gears	

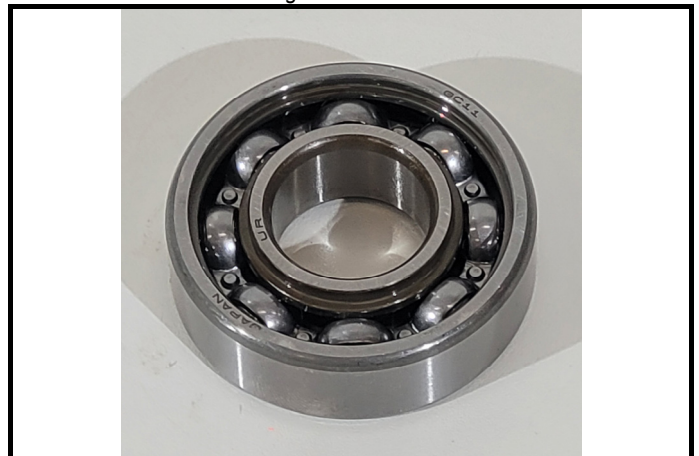
F8-1) Arbre secondaire
Pinionshaft / MainshaftF8-2) Roulement gauche de l'arbre secondaire
Left mainshaft bearing

F8-3) Roulement droit de l'arbre secondaire
Right mainshaft bearing



F8-4) Roulement à aiguilles des rapports
Ratio needle bearings

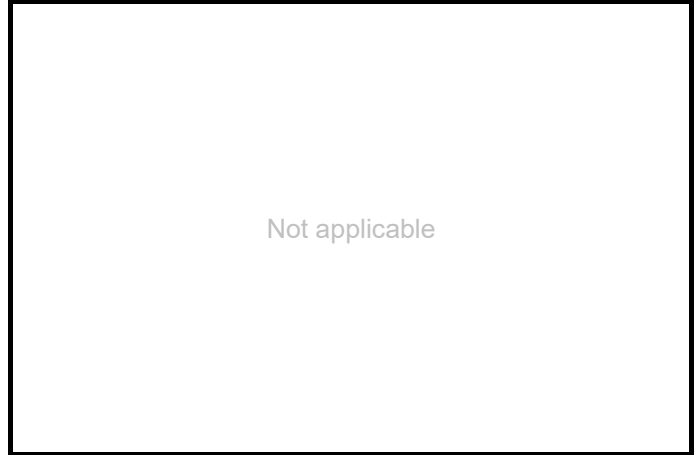

F8-5) Moyeu
Hub

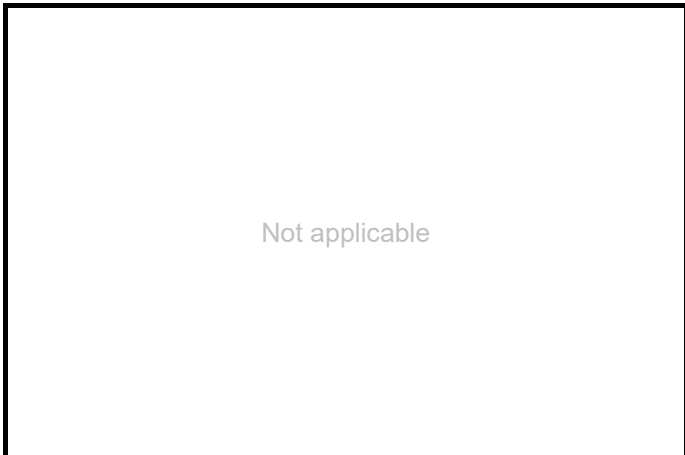

606. MECANISME DE SELECTION DES RAPPORTS / GEAR SELECTION MECHANISM

a) Matériau des fourchettes incluant l'axe Material of selector forks incl. axle	Acier Steel				
b) Masse des fourchettes n°1 / 2 / 3 Weight of forks n°1 / 2 / 3			126 / 113 / 107		± 5 g
c) Masse axe de fourchettes n°1 - 2 Weight of shaft gear shift fork	88	± 5 g		d) Diamètre axe de fourchettes Forks axle diameter	13.95 ± 0.1 mm
e) Epaisseur des doigts de fourchettes Forks finger thickness	5.8	± 0.1 mm		f) Diam. pions de guidage de fourchettes Forks locating pin diameter	7.96 ± 0.1 mm
g) Matériau de l'assemblage du barillet Material of selector barrel assembly	Acier Steel			h) Masse de l'assemblage du barillet Weight of selector barrel assembly	556 ± 5 g

F9-1) Fourchette n°1
Selector forks n°1F9-2) Fourchette n°2
Selector forks n°2F9-3) Fourchette n°3
Selector forks n°3

F9-4) Axe de fourchette n°1
Fork's axle n°1



F9-5) Axe de fourchette n°2
Fork's axle n°2



F9-5) Assemblage du barillet
Selector barrel assembly



F9-5) Assemblage du barillet
Selector barrel assembly

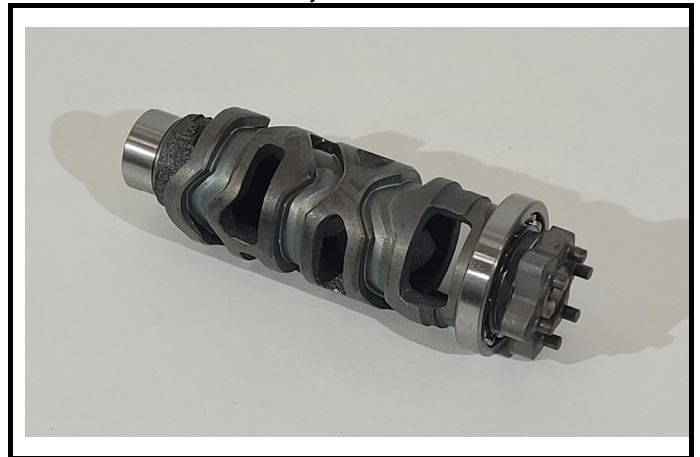



FEDERATION INTERNATIONALE
DE L'AUTOMOBILE

XC Engine
YAMAHA MT07 2016 - 2023

Homologation N°

2023-06-XCAR-MT07

Extension N°

ER 01/01

FICHE D'EXTENSION D'HOMOLOGATION
HOMOLOGATION EXTENSION FORM

Homologation valable à partir du
Homologation valid as from

01/12/2023



ER Erratum / Erratum

TOUTES LES CARACTERISTIQUES FIGURANT DANS CETTE FICHE ANNULENT ET REMPLACENT CELLES FIGURANT DANS LA FICHE DE BASE ET LES EXTENSIONS PRECEDENTES

ALL SPECIFICATIONS FEATURING ON THIS FORM CANCEL AND REPLACE THOSE FEATURING ON BASIC HOMOLOGATION FORM AND THE PREVIOUS EXTENSIONS

328. ECHAPPEMENT / EXHAUST

g) Matière soupape
Valve material

Acier / Inox
Steel / Stainless

h) Masse soupape mini
Min valve weight

24

g